

PRELIMINARY

DV9100

Vision System

FEATURES

- Bar code and 2D code reading in any orientation
- Auto-discrimination of all most common symbologies
- High reading performance on small and low quality codes
- Parcel dimensioning option
- Ready for OCR and Video-coding applications
- Industrial robust architecture
- Sealed camera - no fan
- 2 x 400 W stand-alone illumination
- Sealed lighting system - no fan
- PC based decoding system

APPLICATIONS

- Parcel bar code and 2D code reading
- Complex reading applications
- Parcel OCR and Video-coding
- Postal applications
- Distribution applications

GENERAL DESCRIPTION

The **DV9100** Vision System represents Datalogic's solution for high performance linear and 2D code reading through Vision Technology.

Datalogic's **DV9100** camera system is available today in 2 versions. The new compact camera version and the standard version, that includes internal optical path.

This unique range of solutions allows Datalogic to provide always the best solution for each specific application and environment.

The **DV9100** compact version camera, thanks to its light weight and reduced size represents the ideal solution when high flexibility is required and is ready for multi-side applications. The standard case camera, thanks to totally sealed optics and a reduced need for adjustment and settings, represents the ideal solution for extremely dusty environment and for standard top-side reading applications.

The **DV9100** system, with its advanced decoding system, is able to satisfy the widest range of bar code and 2D code reading applications.

Thanks to high quality optics and advanced electronics, Datalogic's **DV9100** camera captures high quality grey scale images of parcels transported on fast conveyors. As a result of its unique auto-focus technology, the system can cover a large depth of field, allowing minimum gap to be maintained between the parcels. These images perfectly suit the most advanced OCR processors and video-coding systems. The high quality images are processed by the **DV9100** decoding system, a powerful PC-NT based image processor able to provide fast and reliable decoding of all captured bar codes and 2D codes, solving the most complex reading applications.

Datalogic's market leadership in laser based omni-directional reading systems for parcel sorting and tracking applications is now reinforced by the new Vision System line. Datalogic's leadership in both technologies put it in the position to provide always a higher value to its customers.



SYSTEM ARCHITECTURE

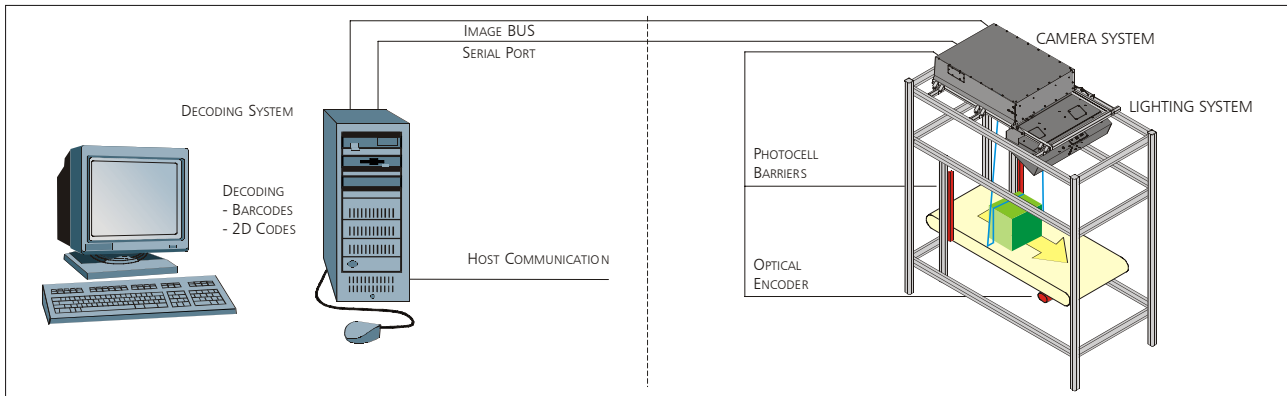

SYSTEM COMPONENTS

DV9100 CAMERA SYSTEM

The DV9100 CCD Camera represent the state-of-the-art in the vision technology applied to parcel identification.

The DV9100 camera is available in two different designs to provide the best answer to different application requirements. The standard DV9100 camera is based on an internal optical path architecture. With this solution the camera system can be installed at a convenient height above the belt (normally 1.5-1.7 m) with no need for external mirrors. The complete optical parts are sealed inside the camera case in a 100% dust proof area. The Standard DV9100 camera can be installed in extremely dusty environment and, not requiring external cooling fans and filters, requires only minimum maintenance.

In the compact DV9100 camera, the case does not include internal optical path and external mirror are used. The camera compactness and lightweight makes installation easier and the increased level of flexibility overcome possible installation constraints. The DV9100 compact camera can be easily installed in alternative configurations allowing multi-side reading configurations.

The two DV9100 models are completely compatible in terms of connectivity and functionality. Both cameras are equipped with the fastest 6K pixel sensors and features Datalogic real time focusing systems able to focus the camera with unbeatable level of accuracy and repeatability.



LV9100 LIGHTING SYSTEM

The LV9100 is the newest generation of lighting systems in the 9000 series of Datalogic products. Based on two 400 W high pressure sodium vapour lamps the LV9100 features innovative power supply units able to increase the lamp efficiency and light uniformity. Thanks to this new technology the power supply units does not require external cooling fans and air filters, increasing the reliability level of the units and reducing the required maintenance. LV9100 minimize the installation time thanks to the adjustable brackets and robust supports. Lamp replacement can be performed simply and quickly directly in the installed simply opening the unit output window.

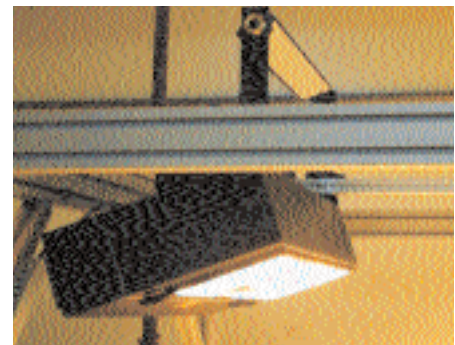

DD9100 DECODING SYSTEM

Datalogic decoding system is based on a standard PC architecture. The use of standard hardware and operating system makes the system extremely robust and flexible. The PC increased computing power is exploited by the decoding software, able to process high speed video signal and to extract the barcode and 2D codes information in the shortest time. All most common 1D and 2D codes can be identified with the maximum reliability.

The decoder also support a parcel dimensioning option. Parcels under scanning can be dimensioned during the reading process.

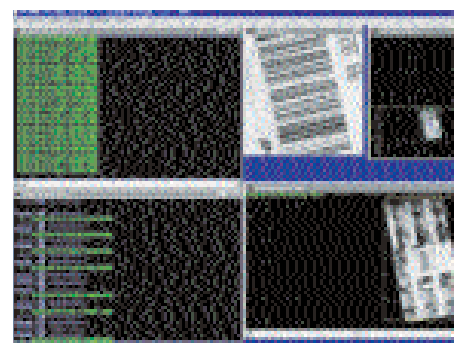

APPLICATIONS AND BENEFITS

BARCODE READING

The DV9100 Vision System offers new opportunities for the omni-directional barcode reading applications.

The characteristics of the imaging process, in fact, make omni-directional reading natural and avoid the limitations of laser based reading systems in respect of code size, height and aspect ratio. The physical redundancy of the barcodes can be exploited by image processing technology increasing the robustness of the system to bad label quality and damaged codes.



2D CODE READING

Thanks to DV9100 Vision System the unattended reading of 2D codes in the logistic processes is now an affordable reality. The DV9100 reads the most common 2D codes, both stacked (e.g. PDF417) and matrix (e.g. Datamatrix, QR Code) with no regards to code orientation, with the same level of reliability reached for standard barcodes. Also Postal codes (e.g. Postnet, Planet, 4 State) can be easily identified by the system.



OCR AND VIDEO CODING

Datalogic supplies a camera solution dedicated to OCR applications, the DV9000 Vision System. This image acquisition system can acquire parcel images at high speed (up to 100 Mpixel/s) and has been specifically customized to provide high quality grey-scale images of the different resolution (usually from 130 to 200 dpi) and with customized features (e.g. controlled image quality and square pixel).

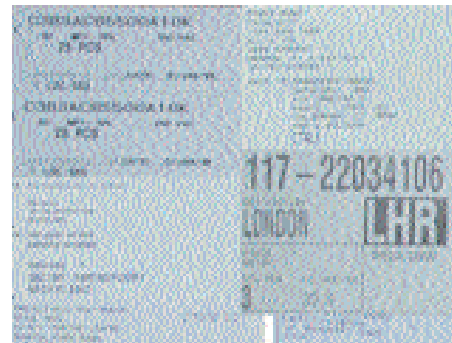

PARCEL DIMENSIONING

Vision technology enables the standard Datalogic decoding system to support the object dimensioning option. The parcel dimensions can be detected by the DV9100 during the scanning process. System precision and repeatability are application dependant and can suit most applications where the detection of the object dimensions is required



SPECIFICATIONS

CAMERA SYSTEM

POWER SUPPLY:	90-127 and 187-250 Vac; 50 to 60 Hz
POWER CONSUMPTION:	150 W
IMAGE RESOLUTION:	130 - 250 dpi, (application dependant)
CONVEYOR COVERAGE:	Up to 1100 mm (43 in)
DEPTH OF FIELD:	Up to 1000 mm (39 in)
CONVEYOR SPEED:	Up to 2.5 m/s
SUPPORTED LENSES:	High quality commercial lenses and Datalogic high quality custom lenses
IMAGE STANDARD:	8 bit grey level image
VIDEO INTERFACE:	Parallel 16 bit LVDS bus (32 bit LVDS available on request)
COMMUNICATIONS:	Port1, Port2, Port3: RS-232 Port 4: RS-485 full duplex
DIGITAL INPUTS:	3, opto-insulated
DIMENSIONS LxWxH	
Standard:	800x1095x264 mm
Compact (low res):	520x589x250 mm
Compact (hi res):	520x647x250 mm
WEIGHT (APPROX)	
Standard:	83 Kg
Compact:	26 Kg
OPERATING TEMP.:	0° to 40° c
STORAGE TEMP.:	-20 to 70° c
HUMIDITY:	Up to 95% non condensing
PROTECTION CLASS:	IP60 (optical section)

LIGHTING SYSTEM

LIGHT SOURCE:	2 x 400W regulated high-pressure sodium lamps
POWER SUPPLY:	90-270 Vac; 50 to 60 Hz
POWER CONSUMPTION:	1000 W max.
DIGITAL OUTPUT:	1, opto-insulated
DIMENSIONS LxWxH:	461x1000x160 mm
WEIGHT (Approx):	28 Kg
OPERATING TEMP.:	0° to 40° c
STORAGE TEMP.:	-20 to 70° c
HUMIDITY:	Up to 95% non condensing
PROTECTION CLASS:	IP60 (optical section)

DECODING SYSTEM

POWER SUPPLY:	90-265 Vac; 50 to 60 Hz
POWER CONSUMPTION:	300 W max.
LABEL ORIENTATION:	Full omni-directional 360 degrees
READABLE BARCODES:	Code 128, Code 39, Interleaved 2/5, EAN/UPC and all popular barcodes
READABLE 2D CODES:	PDF417, Datamatrix, Maxicode and all popular 2D codes. Postal codes.
OUTPUT INFORMATION:	Decoded label, object dimension (opt.)
COMMUNICATION:	Serial RS232
DIMENSIONS:	Mini tower case
OPTIONS:	I/O board, RS422/485 board, RS232 board, Monitor, Keyboard, Cabinet

DIMENSIONS

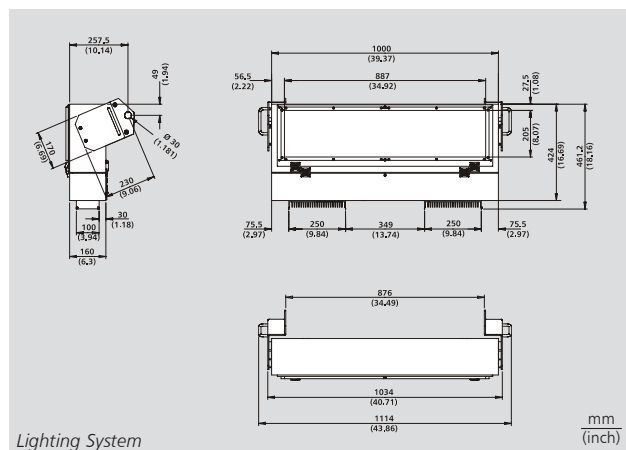
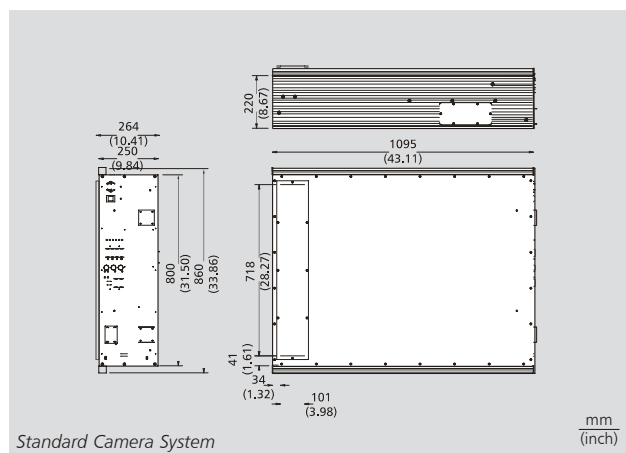
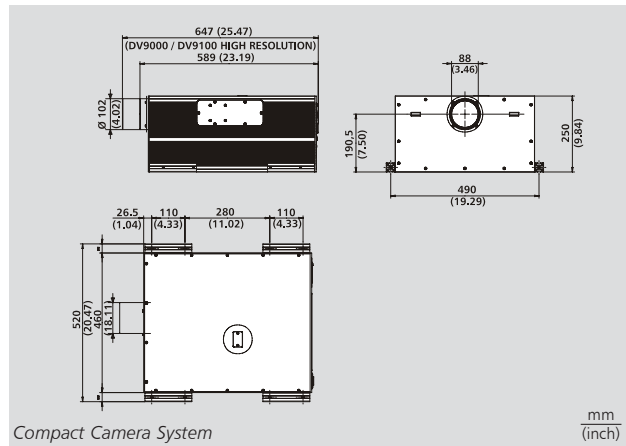

Product and company names and logos referenced may be either trademarks or registered trademarks of their respective companies

We reserve the right to make modifications and improvements

Datalogic S.p.A. Italy

Corporate Headquarters
Tel. +39 051/3147011
Fax +39 051/726562
info@datalogic.it

Sales Italy

Tel. +39 051/3147011
Fax +39 051/3147170
venditeitalia@datalogic.it

Sales International (Central and South America, Far East, Middle East - Africa)

Tel. +39 041/5986511
Fax +39 041/5986510
sales-intl@datalogic.it

Australia

Datalogic PTY LTD.
Tel. +61 3/95589299
Fax +61 3/95589233
sales@datalogic.com.au

Germany

Datalogic GmbH
Tel. +49 7026/6080
Fax +49 7026/5746
info@datalogic.de

Sweden

Datalogic AB
Tel. +46 40/385000
Fax +46 40/385001
info@datalogic.se

Austria

Datalogic Handelsges. mbH
Tel. +43 2236/258820
Fax +43 2236/258825
office@datalogic.co.at

Japan

Izumi Datalogic Co., Ltd.
Tel. +81 78/3033400
Fax +81 78/3033402
jklmarke@izumi-datalogic.co.jp

United Kingdom

Datalogic UK Ltd.
Tel. +44 1582/464900
Fax +44 1582/464999
enquiries@datalogic.demon.co.uk

Denmark

Datalogic AB
Tel. +45 70/239970
Fax +45 70/239972
info@datalogic.se

Netherlands

Datalogic Optic Electronics BV
Tel. +31 346/572888
Fax +31 346/568736
info@datalogic.nl

U.S.A.

Datalogic Inc.
Tel. +1 859/6897000
Fax +1 859/3344970
info@datalogic.com

France

Datalogic France S.A.
Tel. +33 1/60921111
Fax +33 1/60921340
info@datalogic.fr

Spain

Datalogic Iberia
Tel. +34 91/3837755
Fax +34 91/3837962
dliberia@datalogic.it

Datalogic Quality Partner

